

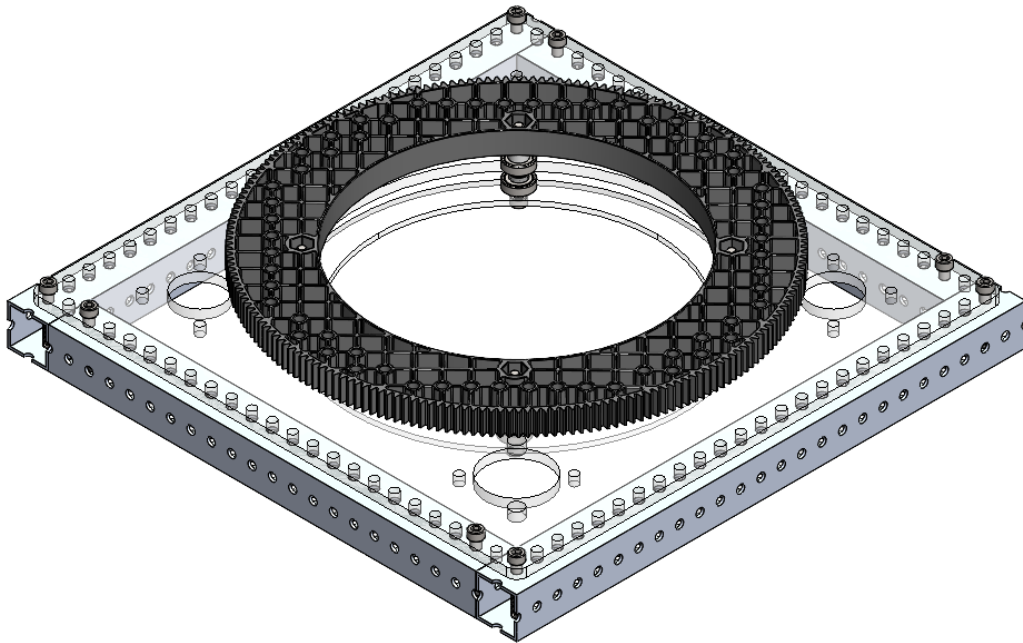

# Turret Kit

(am-5743)

*Assembly Guide*





| Revision # | Date      | Author   | Purpose               |
|------------|-----------|----------|-----------------------|
| 0          | 11/6/2025 | E. Scime | Original Document     |
| 1          | 4/8/2026  | E. Scime | Added Washer Hardware |

|               |               |
|---------------|---------------|
| P. Yeung      | 4/8/2026      |
| Reviewer Name | Date Reviewed |

Need help with an AndyMark product? Contact us at [support@andymark.com](mailto:support@andymark.com).

## Parts & Tools





### Recommended Tools List

| Component                | Part #  | QTY | Photo   |
|--------------------------|---------|-----|---|
| 5/32 Ball End Hex Driver | am-2751 | 1   |  |
| 3/8 Combination Wrench   | am-4961 | 1   |  |

### Parts List

| Component                | Part #  | QTY | Photo   |
|--------------------------|---------|-----|---|
| Base Plate               | am-5744 | 1   |   |
| Support Ring             | am-5745 | 1   |  |
| 5mm Bore 16mm OD Bearing | am-5694 | 8   |  |
| 0.06" Long #10 Spacer    | am-1759 | 4   |  |
| 0.25" Long #10 Spacer    | am-1700 | 4   |  |
| 10-32 Nylock Jam Nut     | am-1063 | 12  |  |
| 200T 20DP Gear           | am-5038 | 1   |  |



| Component                             | Part #  | QTY | Photo   |
|---------------------------------------|---------|-----|---|
| 1x1x1/16" Pre-Drilled Box Tube        | am-5177 | 1   |  |
| 1.5" Long 10-32 Socket Head Cap Screw | am-1014 | 12  |  |
| 5mm Bore 9mm OD Bearing               | am-5693 | 8   |  |
| #10 Washer                            | am-1026 | 4   |  |

## Assembly

### Step 1

Insert [4] 1.5" 10-32 screws (am-1014) into [1] Support Ring (am-5745) and then slip [1] 0.06" Long #10 Spacer (am-1759) onto each screw, for [4] spacers total. Place the assembly down on a table such that the screws will not fall out.

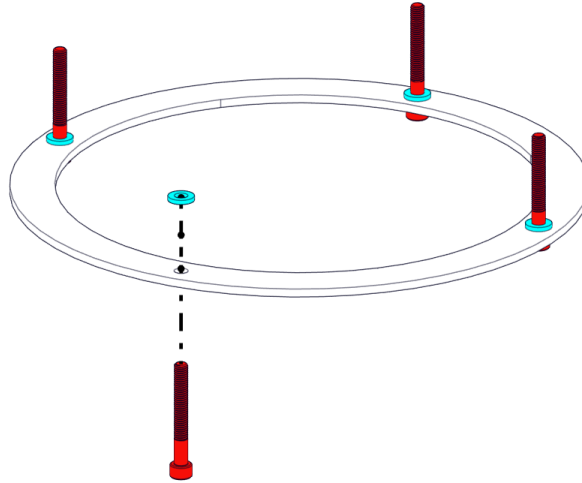

### Step 2

On each screw, place [1] 5mm Bore 16mm OD bearing (am-5694) [4 total] and [2] 5mm Bore 9mm OD bearings (am-5693) [8 total]. Then, slide [1] Base Plate (am-5744) on.

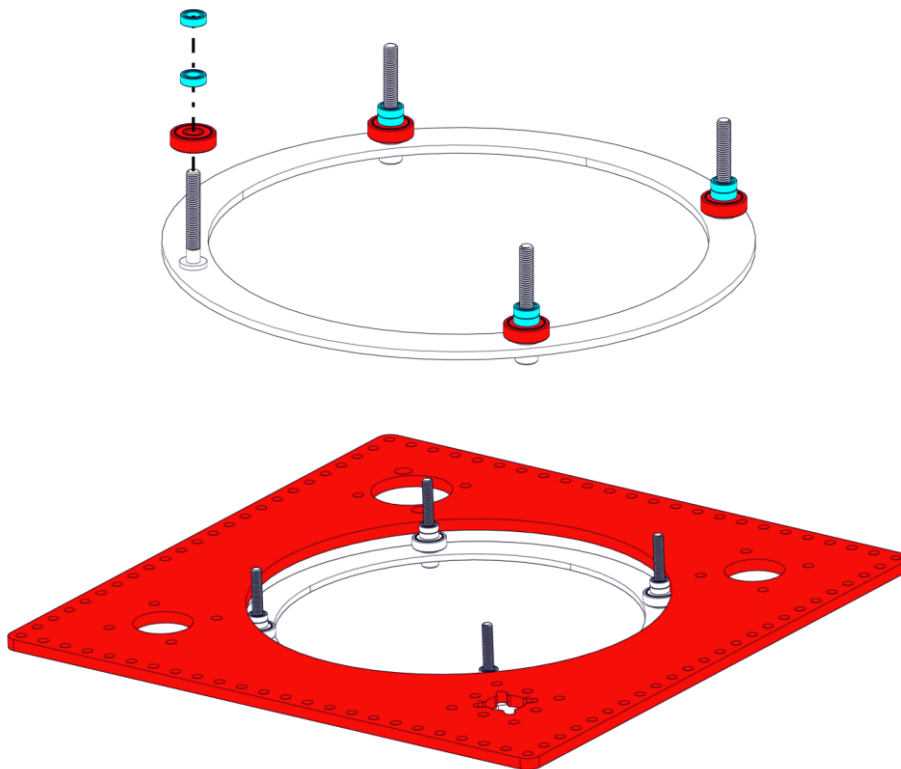

**Step 3**

On each screw, place [1] 5mm Bore 16mm OD bearing (am-5694) [4 total], [1] 0.25" Long #10 Spacer (am-1700) [4 total] and [1] #10 Washer (am-1026) [4 total].

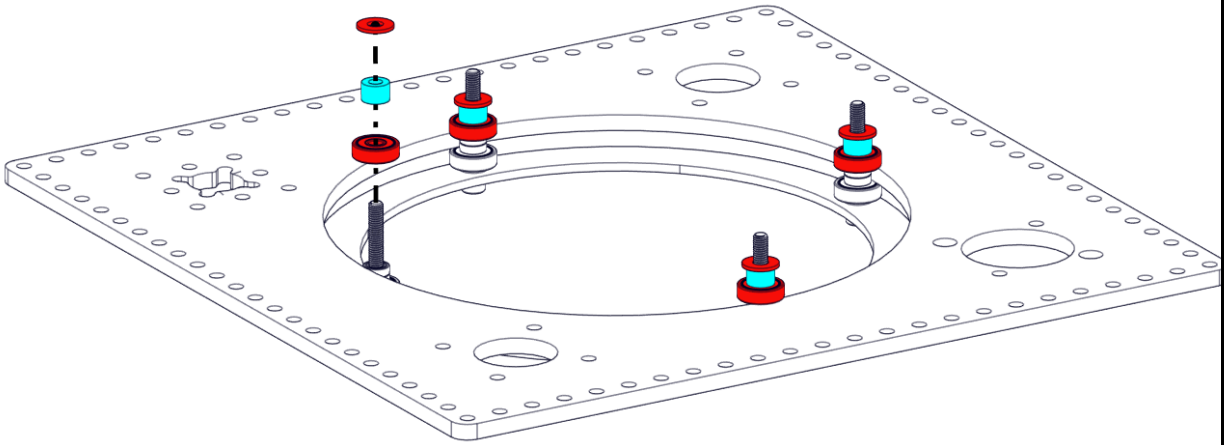

**Step 4**

Place [1] 200T gear (am-5038) onto the assembly from Step 3, using [4] nylock jam nuts (am-1063) to fasten them together.

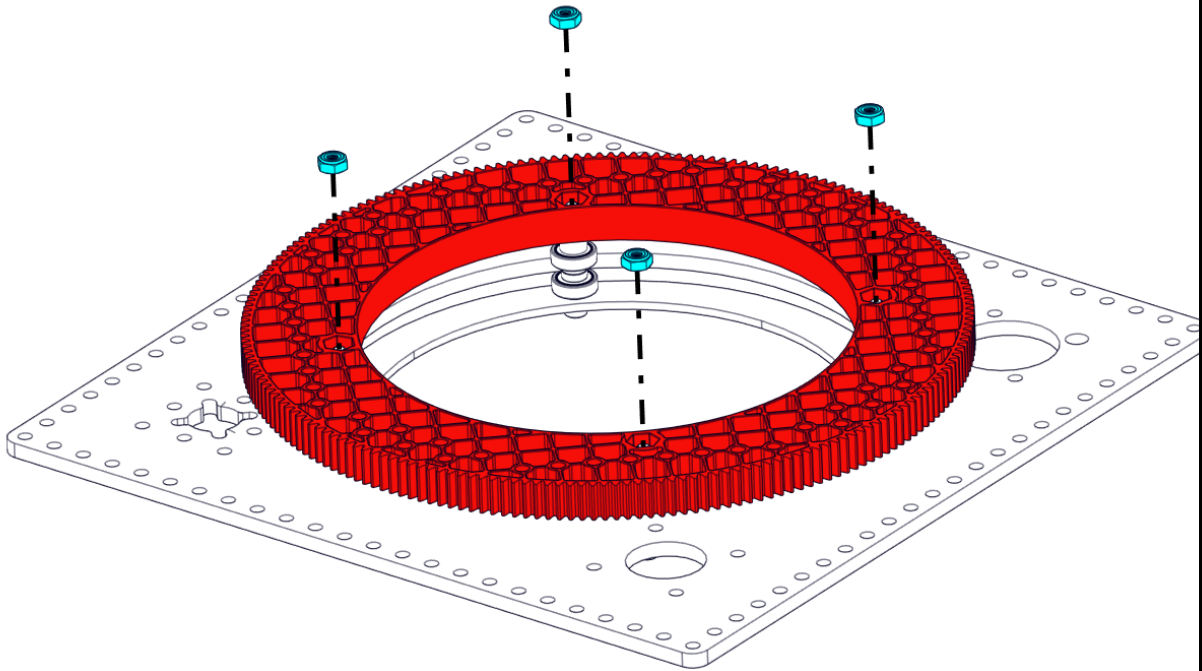



## Motor Input Options

The Turret Kit includes multiple options for motor mounting.

- 1" #10 Bolt Circle (Location A) [for CTR Minion]
- 1.375" #10 Bolt Circle (Location A) [for Kraken X44, Pulsar]
- 2" #10 Bolt Circle (All Locations) [for CIM, NEO, NEO 2, NEO Vortex, & Kraken X60]
- Sport Gearbox (Location C)

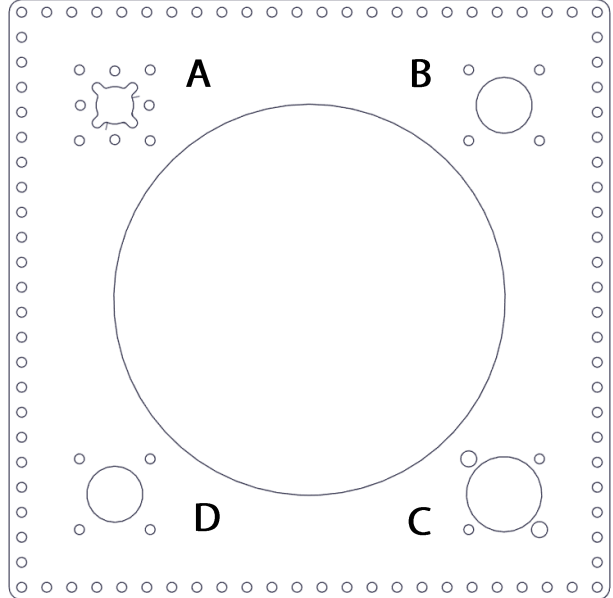

The AndyMark recommended motor input option utilizes the Sport Gearbox.

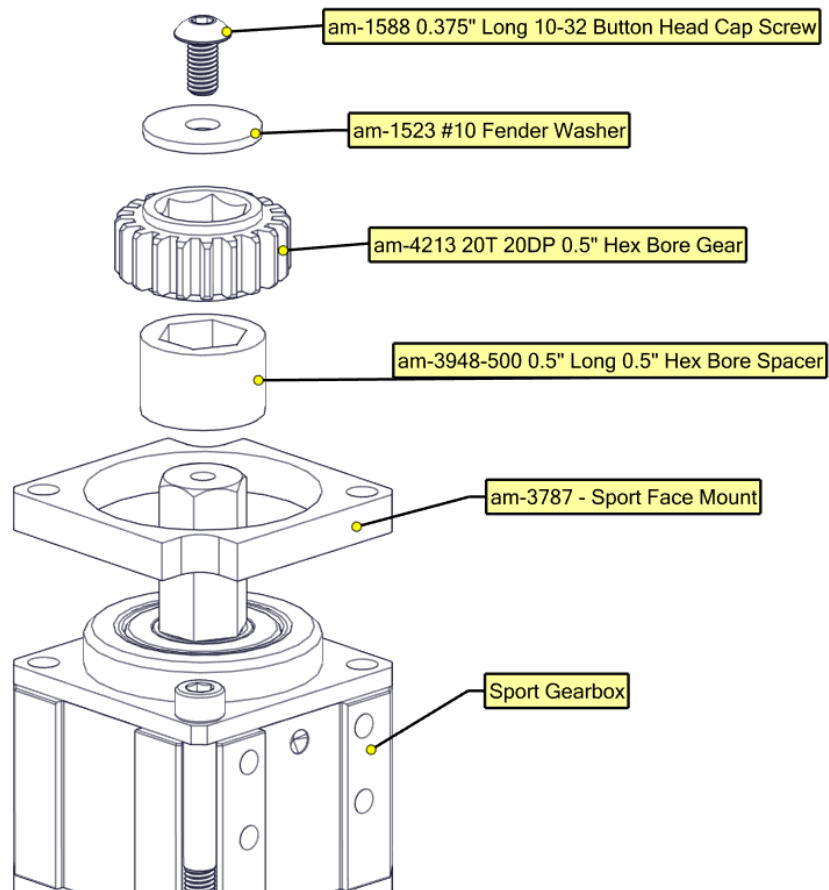

## Sensor Options

There are a number of ways to determine the position of your turret kit.

- The driving motor's internal encoder. Modern FRC motors include an encoder that can be used to determine the relative position of the turret.
- An encoder mounted to any of the four motor mounting locations with a 20 tooth, 20DP gear attached can be used to determine the relative or absolute position of the turret.
- A pair of encoders at two different motor mounting locations, utilizing a 3D printed bracket (available on the Turret Kit Product Page) to allow for the use of a 19T 20DP gear on one and a 21T 20P gear on the other. The absolute position of the turret can then be determined using Chinese Remainder Theorem (CRT).

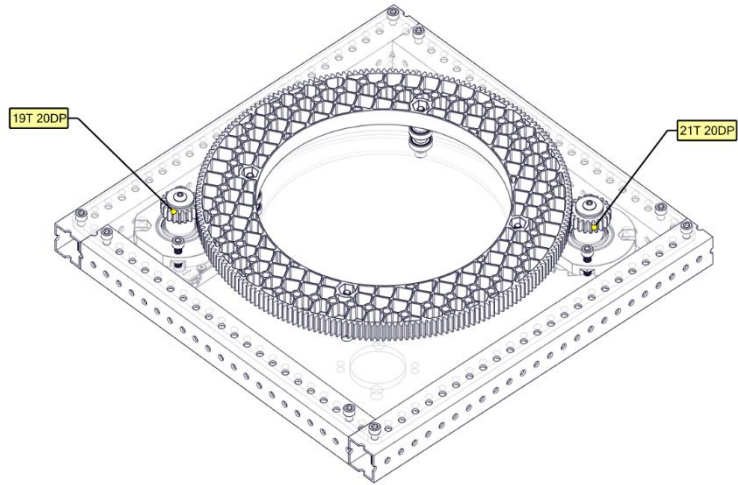

Below is an Example stackup for usage of the CRT.

